

Click object to rotate

Pro



Wideband 40mm LNB with Horizontal/Vertical ports, LO 10.41 GHz (UK)

IDLP-WDB02-0OPRO-OPP

Item: 5586

Specifically designed to meet the increasing demand of DTH operators for lower cost MDU and Multi-tuner Home Gateway installations. This professional wideband LNB is based on a single 10.41 GHz local oscillator, delivering outstanding RF performance over the entire frequency range (L-band) and for the signals at the two output ports for the vertical and horizontal plane combined with a greater immunity against terrestrial/4G interferences.

Manufactured to the highest industry quality standards and designed to meet strict specifications, this LNB is an ideal solution for a cost-effective reception of one satellite and its distribution to multi-tuner home gateways or to compatible Unicable II (dCSS) wideband multiswitches.

Main Features:

- Low Phase Noise, DVB-S2 (HDTV) compliant
- Low Noise Figure
- Low Power Consumption
- High Cross Polarization Isolation
- High Frequency stability
- Greater immunity against 4G interferences

Technical data

Input frequency range	10.7 GHz ~ 12.75 GHz
IF frequency range	290 MHz ~ 2340 MHz
Noise figure	0.7 dB typ. (1 dB max.)
LO frequency	10.41 GHz
LO accuracy @ 25 °C	±1 MHz
LO temperature drift	±2 MHz
LO phase noise @ 10 kHz	-80 dBc/Hz max.
Conversion gain	50 dB ~ 60 dB min.
Gain variation (over full band)	±0.5 dB @ 27MHz
Image rejection	40 dB min. (8.05 GHz ~ 10.1 GHz)
1 dB compression point (@ output)	0.0 dBm min.
Cross polarization isolation	25 dB min.
Output VSWR	2.5 : 1
In band spurious level	-60 dBm max.
Current consumption	150 mA max. @ 11 V ~ 20 V
Operating temperature	-30 °C ~ +60 °C
Output impedance	75 Ω
Output connector type	F-Type (female)
Weight	110 g

Logistical info

Packaging dimensions (W x D x H)	6.5 cm x 6.5 cm x 13.8 cm
Packaging weight	0.136 kg
Quantity per carton	50 pcs
Carton dimensions (W x D x H)	36.7 cm x 34.7 cm x 29.5 cm
Carton weight	9.1 kg
Quantity per pallet	900 pcs

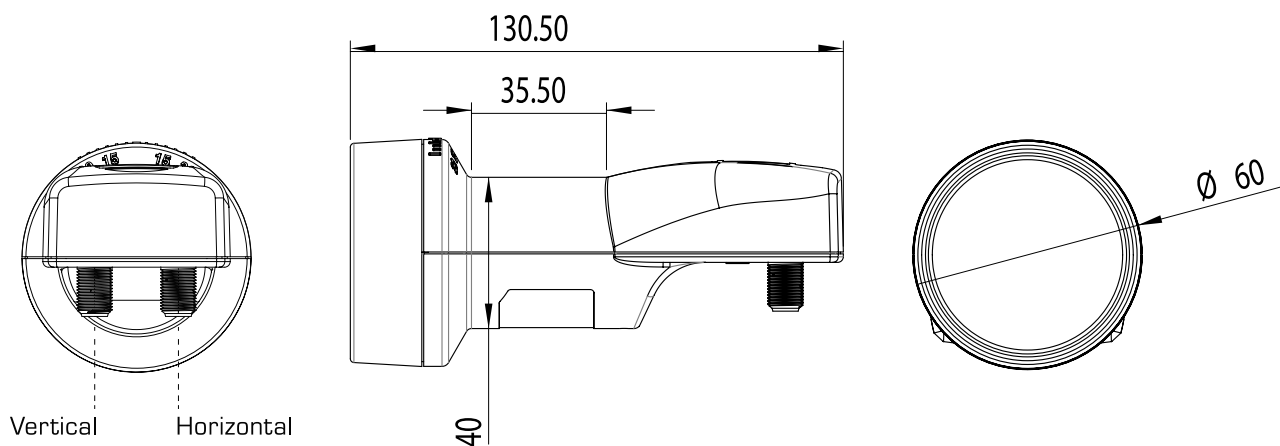

For purpose of brevity, some product descriptions in this sheet remain at platform level and may not be referred to as detailed datasheets of the products. Inverto Digital Labs reserves the right to amend, omit or add products, product-lines, and / or features without notice.

For further details contact: sales@inverto.tv

FTA Communication Technologies S.à r.l. Tel. +352 264 367 1 Fax. +352 264 313 68

