

Click object to rotate

Pro

Single High-Band Circular 41mm LNB (LO10.60 MHz)

IDLB-SINR41-H1060-OPP

Item: 3130



Specifically designed for the European DTH markets, this LNB provides optimized reception capabilities for receiving circular polarized signal on the high band. It is factory set for easy connectivity with any LO 10.60 Preset Set-top boxes, fully supports High Definition transmissions and provides excellent Noise Figure performance. It enables the reception of signal from one satellite and its distribution to a single tuner Set-top box, it is manufactured to the highest industry quality standards and is designed to meet strict specifications. This LNB is an ideal solution for the satellite broadcast reception across Europe.

Main Features:

- LO frequency 10.60 MHz Low Noise figure
- Low phase Noise HDTV-DVBS2 compliant
- Low Noise figure
- Low Power consumption
- High Cross-Pole performance
- High Frequency stability

Technical data

| | |
|-------------------------------------|--------------------------|
| Low Band Input Frequency Range | . |
| Low Band Output Frequency Range | . |
| Low Band LO Frequency | . |
| High Band Input Frequency Range | 11.7 ~ 12.75 GHz |
| High Band Output Frequency Range | 950 ~ 2150 MHz |
| High Band LO Frequency | 10.60 GHz |
| Noise Figure | 0.3 dB Typ. (0.7dB Max.) |
| LO Initial Accuracy | +/- 1.0 MHz Max. |
| LO Temperature Drift | +/- 3.0 MHz Max. |
| Phase Noise (@ 10 kHz) | - 80 dBc / Hz Max. |
| Conversion Gain | 55 dB Min. |
| Gain Ripple (Over 26MHz Bandwidth) | +/- 0.75 dB |
| Gain Variation (Over Full Band) | +/- 4 dB Max. |
| Image Rejection | 40 dB Min. |
| 1 dB Compression Point (@ Output) | 0.0 dBm Min. |
| Cross Polarization Isolation | 22 dB Min. |
| Polarization Selection (Right Hand) | 11.0 ~ 14.0 V |
| Polarization Selection (Left Hand) | 16.0 ~ 20.0 V |
| Control Signal Cc (Band Switching) | . |
| Output VSWR | 2.5 : 1 |
| In-Band Spurious | - 60 dBm Max. |
| Current Consumption | 110 mA Max. @ 11 ~ 20 V |
| Operating Temperature | - 25 °C ~ + 60 °C |
| Output Impedance | 75 Ω |
| Output Connector | F-Type (Female) |
| Weight | 130 g |

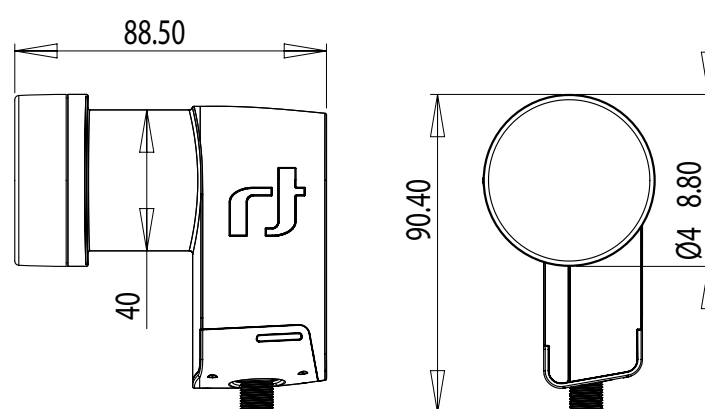

For purpose of brevity, some product descriptions in this sheet remain at platform level and may not be referred to as detailed datasheets of the products. Inverto Digital Labs reserves the right to amend, omit or add products, product-lines, and / or features without notice.

For further details contact: sales@inverto.tv

FTA Communication Technologies S.a.r.l. Tel. +352 264 367 1 Fax. +352 264 313 68

